

AMSAT Fox

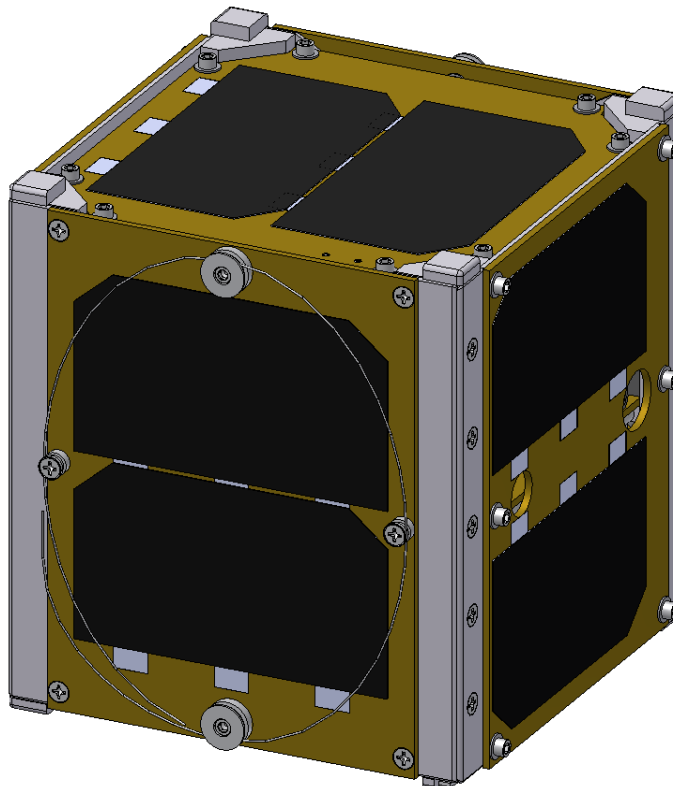

Project *Fox* is AMSAT's answer to the satellite communities' growing interest in CubeSats. A CubeSat is a small satellite based on a basic 4-inch (10cm) cube shape. AMSAT is developing a family of these satellites to take advantage of new launch opportunities that are now available for CubeSat educational and scientific missions.

The first members of this new family are the *Fox-1* satellites as shown in the drawing below. These are currently being developed by our all-volunteer, AMSAT engineering team. They will use 70cm for uplinks and 2 meters for downlinks. Each satellite will be able to operate as both an FM analog repeater and in digital data mode. The satellites are magnetically stabilized using a permanent magnet and hysteresis rods.



Each face of the satellite has a pair of high-performance, space-rated solar cells. These solar cells drive maximum-power-point-tracking, DC-to-DC converters that will wring out as much power as possible from the cells. This power is used to charge a 10 watt-hour NiCd battery. The power system can provide a little over 2 watts continuously, even in eclipse, and quite a bit more peak power if needed.

The antennas are spring-wire whips and the VHF one is shown in its stowed position wrapped around the solar panel. The UHF antenna is on the opposite face. After deployment in orbit, they will spring out in opposite directions. Each antenna will operate as a dipole. On 70cm, the whip and the satellite body form the dipole. On 2 meters, the whip is half of the dipole and both the satellite body and the 70cm whip make up the other half. The whips are aligned with the Z-axis of the satellite which is magnetically stabilized to help minimize QSB.

It is quite a challenge to fit all of the spacecraft electronics into such a small package! The engineering team has come up with the design shown below. The satellite consists of a stack of nine printed circuit cards with bus connectors running up the stack.

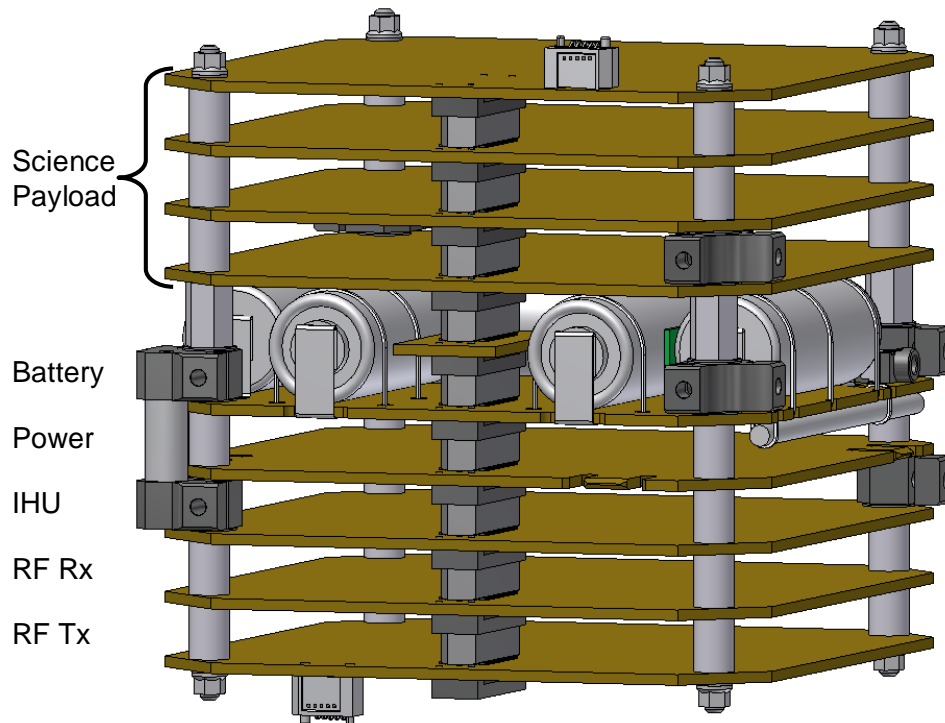

At the bottom of the stack is the RF Tx card which is the 2-meter transmitter. It will provide a minimum of 400mW output that will make the satellite very easy to hear. Next up is the RF Rx card that has a very sensitive 70cm receiver using a low-noise preamp and a surface-acoustic-wave filter to minimize interference. The Internal Housekeeping Unit or IHU card provides the brains

of the satellite and it includes a modern 32-bit microprocessor with 128K of program memory and 16K of RAM. The IHU card also includes a non-volatile, magneto-resistive memory (MRAM) device that can store up to 128K of telemetry and experiment data. The Power card has the DC-to-DC converters for the solar panels. Finally, the Battery card has the NiCd battery and an active temperature control system. The control system is intended to prevent damage to the batteries from the temperature extremes that will be seen inside the satellite. Mounted to the bottom of the Battery card are the magnetic hysteresis rods used to stabilize the satellite along with the permanent magnet shown along the left side of the stack.

The remaining four cards are available for a science payload. This represents about 35% of the total satellite volume. This capability is intended to allow AMSAT to collaborate with universities to develop and fly science missions while providing a free ride for our ham radio transponder. AMSAT intends to build and fly at least four *Fox-1* type satellites.

Our first satellite, *Fox-1A*, will carry an experiment developed by students at Penn State University. This was an AMSAT-sponsored, senior design project. The experiment will determine if we can measure the satellite's spin rate and off-axis wobble using a 3-axis, micro-electro-mechanical (MEMS) gyroscope.

AMSAT applied to NASA's ELaNa program for a free launch of this satellite as an education mission and we were accepted into the program in February of 2012. We requested a launch into a 650km (just over 400 miles), sun-synchronous, circular orbit in mid to late 2013. In this orbit, the FM repeater should be easily accessible with an HT and a hand-held Yagi just like AO-51 – but from a satellite that is just 1/15th the size!

We are currently working with universities to develop joint missions for the remaining *Fox-1* satellites and these would be expected to be launched in the 2014 and beyond time frame.

The next members of the *Fox* family will be the *Fox-2* CubeSats. We plan to develop a software-defined transponder (SDX) for these satellites that will allow an unprecedented level of flexibility. The SDX will support a variety of linear transponder modes, FM modes, and much higher data rates on digital modes. The SDX capability would be combined with a more advanced IHU processor and larger solar panels in order to provide the needed power. We will use what we learn in developing the first generation *Fox-1* CubeSats and apply it towards making *Fox-2* a very powerful satellite in a very small package!



How can you help AMSAT build and launch *Fox-1*?

AMSAT needs your help to build and launch *Fox-1*. AMSAT welcomes members from around the world. In addition to memberships, AMSAT needs donations toward the Fox project for the first two Fox satellites, and others that will follow in the future. Donations may be made in many ways:

- Online through the <http://www.amsat.org/> web site
- By telephone. Call Martha at the AMSAT office on 1-888-322-6728 toll-free, or +1 301 822 4376 from anywhere
- By mail:

AMSAT
10605 Concord Street, Suite 304
Kensington, MD 20895
USA

AMSAT is a 501(c)(3) non-profit research and education organization under the US Internal Revenue Code. Donations may be tax deductible to the extent allowed by law.

This document was a collaborative effort by Patrick Stoddard [WD9EWK/VA7EWK](#), Mal Pizzey VK2MAL, and Anthony Monteiro AA2TX. AMSAT trademarks used with permission.